

Bloms AB



LOGIFLEX STACKERS

LF/LFS - ELF/ELFS - SELF/SELFSMINI - SELF/SELFSMAXI



MANUAL LOGIFLEX

ELECTRIC LOGIFLEX

FULLY POWERED LOGIFLEX MINI

FULLY POWERED LOGIFLEX MAXI



Logiflex – the stacker constructed to lift up your work

Our Logiflex series of high-quality stackers is designed to make material handling smooth, safe and efficient

With Logiflex stackers you get a very flexible solution to lift and transport different items on pallets.

Our stackers are available in manual, electric and fully powered versions, as well as with standard or straddle legs. The manual and electric versions also come in stainless steel.

Common for all is the very strong and compact design, low own weight and easy operation, which means the stackers work very well in narrow spaces. This is often an advantage our customers value very much. In addition, the stackers can drive

with the handle in upright position. Another important feature in terms of flexibility is the adjustable fork carriage. This allows you to switch between different attachments for your Logiflex, and in this way, you can solve different material handling tasks with one machine.

The Logiflex stackers work well across all types of industries and companies – and your specific situation determines the degree of automation you need.

We can also customise the products to meet your exact needs.

Very solid construction to ensure long operating life

Option for models with electric lift: Remote control - with 200 mm lowering safety precaution

Instant stop (forks stops quickly and precisely)

Transparent safety screen

Compact design and easy to manoeuvre

Anti crush button (for models with electric propulsion)

Control buttons centrally placed

Internal charger and battery hour deck

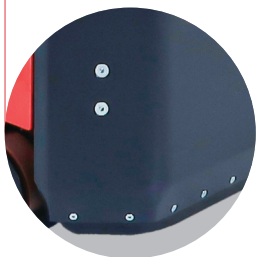

Rear cover in metal to avoid breaking



Foot protectors and shielded chains



Ergonomically correct handle with safety switch

Manual Logiflex (LF/LFS)

If you need a solution to lift and/or transport pallets to a limited extent, the manual Logiflex is a good choice.

This model has manual propulsion and pumping (lifting and lowering), and therefore it is recommended for light weight lifting, or when you only need to use the function on weekly basis.

The manual Logiflex has several safety features to protect the operator and the surroundings. The low building height ensures a good view, while operating the machine.

The ergonomically correct handle ensures a proper grip and the shielded chains and foot protectors by the steering wheels also keep the operator safe. It also has assisted steering on the wheels for easy operation.

The capacity of the manual Logiflex stacker is 1000 kg.

We use a special oil for all products, which is tested in cold atmospheres down to at least -10 degrees C.

Electric Logiflex (ELF/ELFS)

The electric Logiflex is a good match if you need to lift, stack or transport heavy pallets on a daily basis.

This model has manual propulsion and electrical pumping (lifting and lowering), which allow you to lift and stack pallets with heavy loads (up to 1200 kg) with little physical efforts.

In addition, it has assisted steering on both wheels, which makes it very easy to operator. This is an important feature with manual propulsion, to protect to operator from physical strain.

The strong construction ensures a long operating life with low maintenance costs, which gives you a solid and reliable solution for your material handling processes.

The electric Logiflex is available with a remote control for lifting and lowering, as well as with level control to ensure correct working height for your working station.

Safety for the operator is always a top priority of our products - see page 3 for all safety features.

The capacity of the electric Logiflex stacker is 1000/1200 kg.

We use a special oil for all products, which is tested in cold atmospheres down to at least -10 degrees C.

AVAILABLE WITH

- ✓ Different fork styles
- ✓ Standard legs
- ✓ Straddle legs
- ✓ Different lifting heights
920-1650 mm
(with or without
telescopic mast)
- ✓ Remote control
- ✓ Level control
- ✓ Stainless steel

STANDARD FEATURES

- ✓ Hand brake
- ✓ Foot protector

AVAILABLE WITH

- ✓ Different fork styles
- ✓ Standard legs
- ✓ Straddle legs
- ✓ Different lifting heights
920-3300 mm
(with or without
telescopic mast)
- ✓ Remote control
- ✓ Level control
- ✓ Stainless steel

STANDARD FEATURES

- ✓ Hand brake
- ✓ Foot protector

Manual Logiflex (LF/LFS)



Electric Logiflex (ELF/ELF5)

Fully powered Logiflex Mini (SELFMINI/SELFS MINI)

The fully powered Logiflex Mini is a perfect match for smaller storage and shopping areas with shorter distances, less operation frequency or lighter weight loads.

It has electrical propulsion and pumping (lifting and lowering), which means you can lift, stack and transport pallets without physical efforts.

This increases the efficiency of your material handling processes and creates a more productive working environment.

The electric propulsion makes the stacker easy to operate and the multi flex feature, which allows you to drive with the handle upright, enables operation in confined areas.

In addition to our standard safety features - see page 3 - our Logiflex Mini is equipped with user-friendly AC-technology (Curtiscontroller) for speed and acceleration settings.

The capacity of the fully powered Logiflex Mini is 1000 kg.

We use a special oil for all products, which is tested in cold atmospheres down to at least -10 degrees C..

Fully powered Logiflex Maxi (SELFMAXI/SELFS MAXI)

With the fully powered Logiflex Maxi, you get a powerful machine with a long operation time per charge - also with heavy loads, long distances and frequent use.

The Logiflex Maxi has electrical propulsion and pumping (lifting and lowering), which means you can lift, stack and transport pallets with heavy loads without physical efforts. It has a very strong construction and a large battery, and the maintenance costs are at a minimum.

If you need to transport pallets in long distances, or lift and stack pallets with heavy loads frequently, we highly recommend this solution. It provides a high level of efficiency, flexibility and safety for the operator as well as the surroundings. See page 3 for all safety features.

Despite its strength and durability, the Logiflex Maxi also has a compact design and easy operation. It has a soft acceleration and precise movements, and with the Curtis controller you can easily pre-set speed, acceleration and deceleration.

The capacity of the fully powered Logiflex Maxi is 1000/1200 kg*.
*1200 kg only up to 1600 mm lifting height.

We use a special oil for all products, which is tested in cold atmospheres down to at least -10 degrees C.

AVAILABLE WITH

- ✓ Different fork styles
- ✓ Standard legs
- ✓ Straddle legs
- ✓ Different lifting heights
920-1650 mm
(with or without
telescopic mast)
- ✓ Remote control
- ✓ Level control
- ✓ Stainless steel

STANDARD FEATURES

- ✓ Motor brake
- ✓ Foot protector

AVAILABLE WITH

- ✓ Different fork styles
- ✓ Standard legs
- ✓ Straddle legs
- ✓ Different lifting heights
920-3300 mm
(with or without
telescopic mast)
- ✓ Remote control
- ✓ Level control
- ✓ Stainless steel

STANDARD FEATURES

- ✓ Motor brake
- ✓ Foot protector

Fully powered Logiflex Mini (SELF MINI/ SELFS MINI)



Fully powered Logiflex Maxi (SELF MAXI/SELFS MAXI)

Quick shift attachments

Some of our Logiflex models are available with the adjustable fork carriage to switch between different attachments. This allows you to use the Logiflex stacker for multiple purposes.



Drum forks
Handling of horizontal drums or reels



Fork styles
Different fork styles for different pallets



Boom
Transporting reels in horizontal position



Platform
Carrying different kinds of goods, also non-palletised goods



Crane arm
Lifting and transporting items with a hook



Drum Turner
Handling standard steel and plastic drum



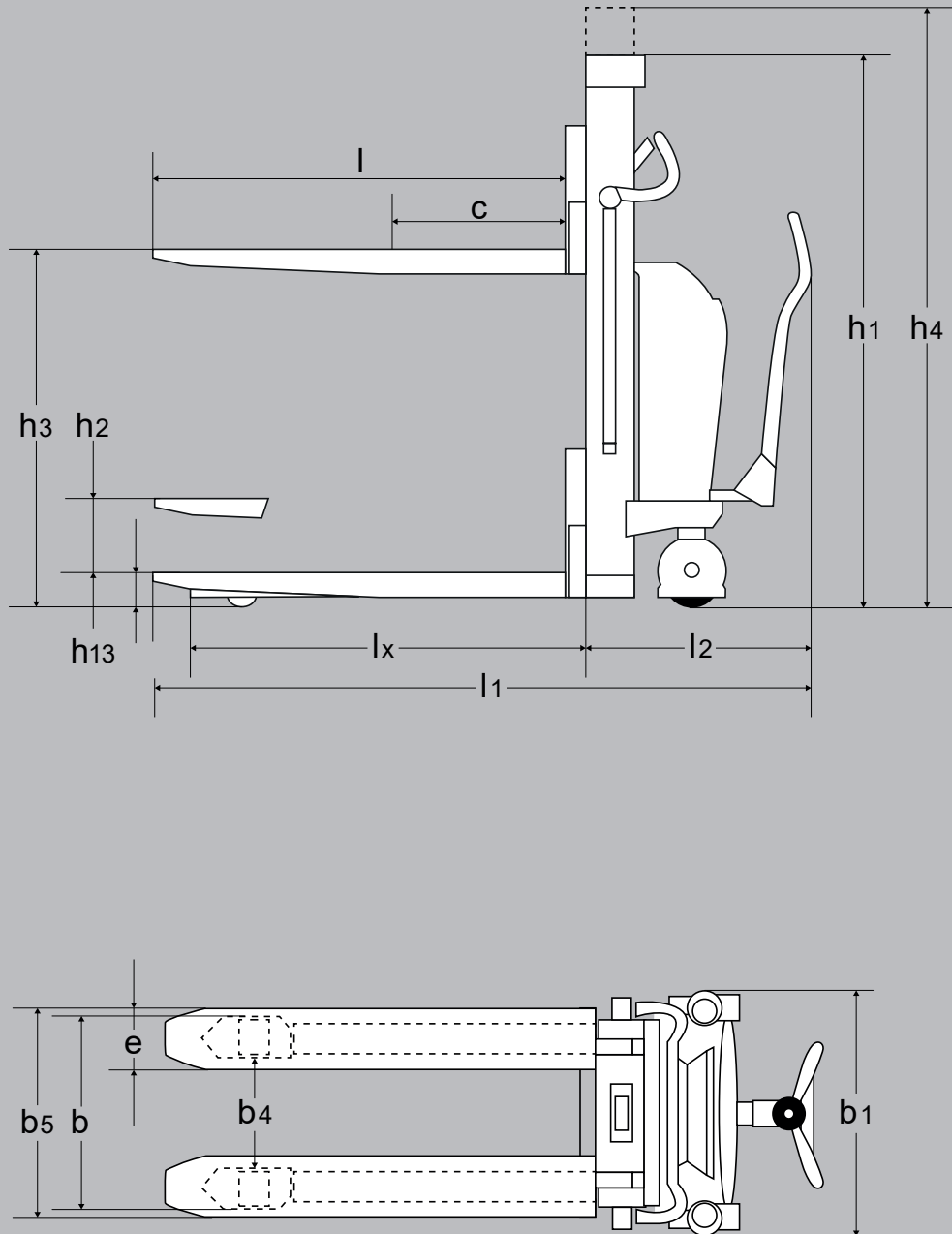

PRODUCT
(measured in mm)

LF MINI

LF MINI

ELF

ELF

ELF

ELF

ELF

ELF

ELF

ELF

ELF

ELF

ELF

SPECIFICATIONS - LOGIFLEX LF MINI + ELF

Adjustable fork carriage ¹		●	●	●	●									
Fixed forks ¹						●	●	●	●	●	●	●	●	●
Capacity in kg		1000 kg	1000 kg	1000 kg	1000 kg	1200 kg	1200 kg	1200 kg	1200 kg	1000 kg	1000 kg	1000 kg	1000 kg	1000 kg ³
Lifting height	h_3	920	1650	920	1650	920	1200	1400	1600	1910	2050	2450	2850	3300
Fork length	l	1067, 1150		1067, 1150		600 ⁴ , 800 ⁴ , 1150, 1520 ⁵								
Overall height	h_1	1330		1330		1530	1730	1930	2240	1530	1730	1930	2240	
Chassis span	b	540, 660		540, 660		540, 660								
Overall width	b_1	680		680						932				
Width between legs	b_4	316, 436	316, 436											
Fork span - wrap-over ²	b_5	350-560				560								
Length without forks	l_2	415		590										
Overall length with 1150 forks	l_1	1675	1685	1860	1870	1800				1800				
Telescopic mast			●		●						●	●	●	●
Overall height	h_4	1330	2025	1330	2025	1330	1530	1730	1930	2240	2490	2890	3290	3740
Lowered height - wrap-over ²	h_{13}	85				90								
Load centre	c	1/2												
Forkwidth - wrap-over ²	e	163												
Run-in length	l_x	1100 with 1150mm forks			1080 with 1150mm forks									
Gangway (pallet: 1200 x 800)	A_{st}	2190 ⁵			2290 ⁵									
Free lift	h_2		330		330						190			
Turning angle of wheels		180°				180°								
Pump motor		1,1kW 12 V												
Lifting speed		normal/quick: 8/26 mm pump			With/without load: 0,05/0,07 m/s									
Lowering speed with/without load		max. 0,05 m/s / max. 0,07 m/s			0,12m/s / 0,04 m/s						0,12m/s / 0,06 m/s			
Weight in kg (without battery)		219 kg	254 kg	238 kg	284 kg	230 kg	241 kg	247 kg	260 kg	270 kg	315 kg	323 kg	337 kg	390 kg

¹ This sheet shows our most popular Logiflex models. Other fork configurations are also available.

² For other fork styles go to p. 23.

³ Load reduction at large lifting height.

⁴ Maximum lifting height 1600 mm with 600 mm forks, maximum lifting height 2450 mm with 800 mm forks.

⁵ Reduced capacity 750 kg. Not available for 1200 kg models.

⁶ Tests show that 1700 mm are enough.

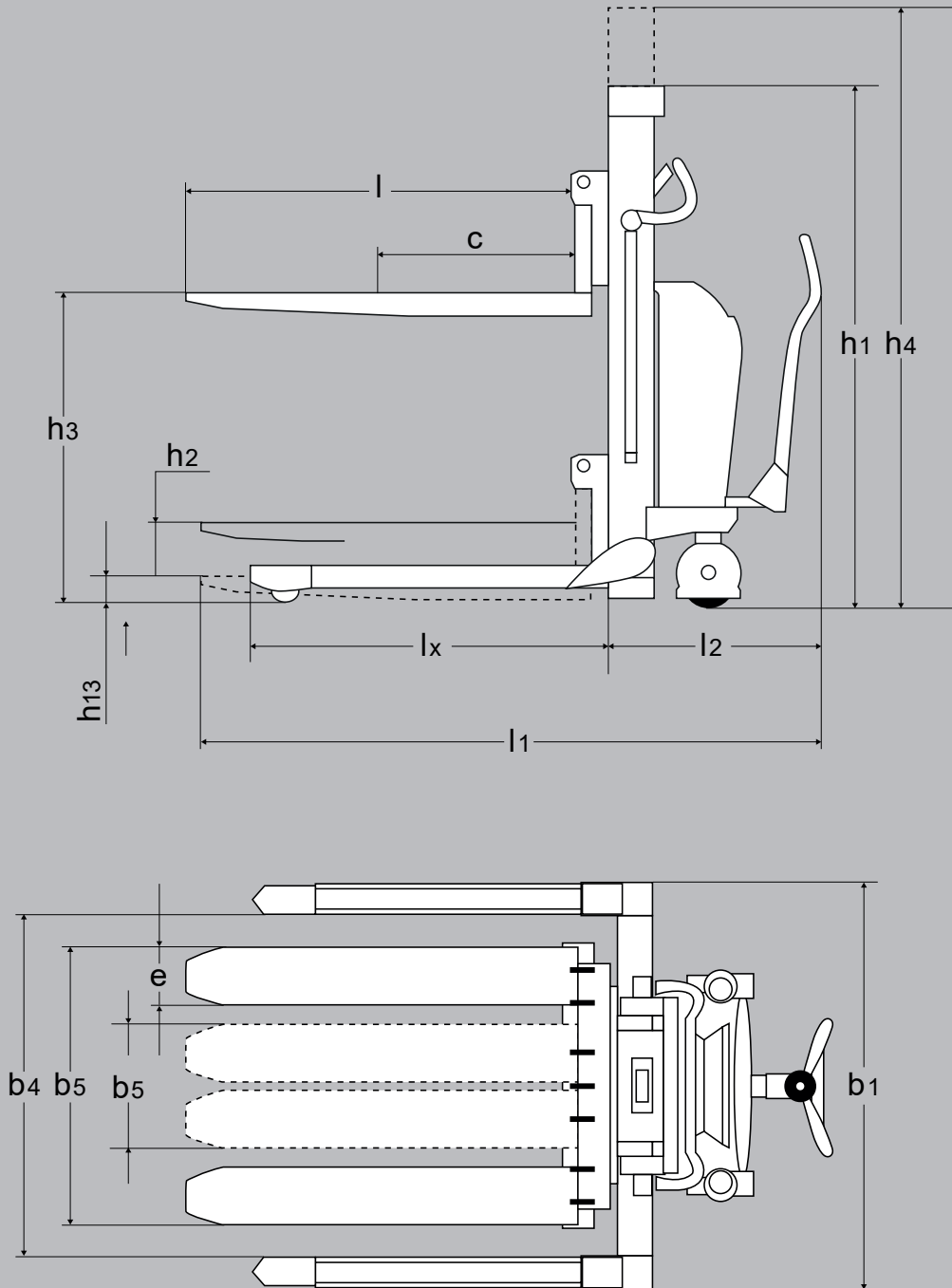

PRODUCT
(measured in mm)

LFS MINI

LFS MINI

ELFS

ELFS

ELFS

ELFS

ELFS

ELFS

ELFS

ELFS

ELFS

ELFS

ELFS

SPECIFICATIONS - LOGIFLEX LFS MINI + ELFS

Adjustable fork carriage ¹		●	●	●	●	●	●	●	●	●	●	●	●	●	
Capacity in kg		1000 kg	1000 kg	1000 kg	1000 kg	1200 kg	1200 kg	1200 kg	1200 kg	1000 kg	1000 kg	1000 kg	1000 kg ³	1000 kg ³	
Lifting height forks: wrap-over/chisel	h ₃	890/870	1620/1600	890/870	1620/1600	890/870	1170/1150	1370/1350	1570/1550	1880/1860	2020/2000	2420/2400	2820/2800	3270/3250	
Fork length	l	600, 800, 1067, 1150, 1520 ³		600, 800, 1067, 1150, 1520 ³		1067, 1200			800, 1067, 1150, 1520 ³			1067, 1150, 1520 ³			
Overall height	h ₁	1330		1330		1530	1730	1930	2240	1530	1730	1930	2240		
Overall width	b ₁	166 + b ₄		166 + b ₄											
Fork span min./max. - wrap-over ²	b ₅	350-560		350-800											
Fork span min./max. - chisel ²	b ₅	230-430		230-680											
Length without forks	l ₂	415		590											
Overall length with 1150 forks	l ₁	1685	1695	1855	1865	1855				1865					
Telescopic mast			●		●						●	●	●	●	
Overall height	h ₄	1330	2025	1330	2025	1330	1530	1730	1930	2240	2490	2890	3290	3740	
Lowered height - wrap-over forks ²	h ₁₃	65													
Lowered height - chisel forks ²	h ₁₃	40													
Load centre	c	l / 2													
Width between legs	b ₄	S: 850-942, M: 942-1124, L: 1124-1306, XL: 1240-1422 ⁴			S: 850-942, M: 942-1124, L: 1124-1306, XL: 1240-1422 ⁴		S: 850-942, M: 942-1124, L: 1124-1306			S: 850-942, M: 942-1124, L: 1124-1306, XL: 1240-1422 ⁴					
Forkwidth - wrap-over ²	e	163													
Forkwidth - chisel ²		100													
Run-in length	l _x	1080 with 1150 and 1067 forks			1080 with 1150 and 1067 forks										
Gangway (pallet: 1200 x 800)	A _{st}	2190 ⁵			2290 ⁵										
Free lift	h ₂		330		330						190				
Turning angle of wheels		180°			180°										
Pump motor		1,1kW 12V													
Lifting speed		normal/quick: 8/26 mm pump			With/without load: 0,05/0,07 m/s										
Lowering speed with/without load		max. 0,05 m/s / max. 0,07 m/s			0,12 m/s / 0,04 m/s						0,12 m/s / 0,06 m/s				
Weight in kg (without battery)		285 kg	320 kg	282 kg	317 kg	282 kg	301 kg	307 kg	311 kg	319 kg	362 kg	369 kg	378 kg	427 kg	

¹ This sheet shows our most popular Logiflex models. Other fork configurations are also available.

² For other fork styles go to p. 23.

³ Reduced capacity 750 kg.

⁴ Tests show that 1700 mm is enough - depends on width between straddle legs.

⁵ Width between straddle legs of more than 1306 mm: Max. capacity 800 kg. Fork length of 1520 mm is not recommended.

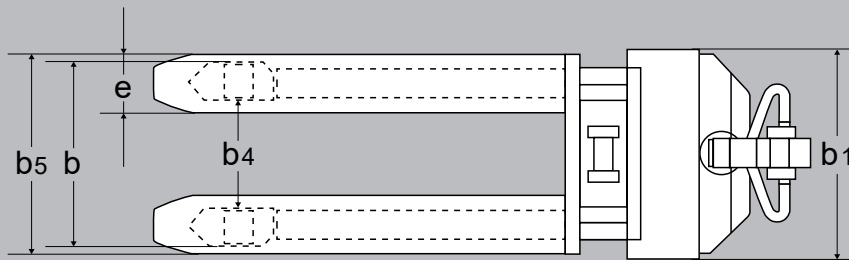
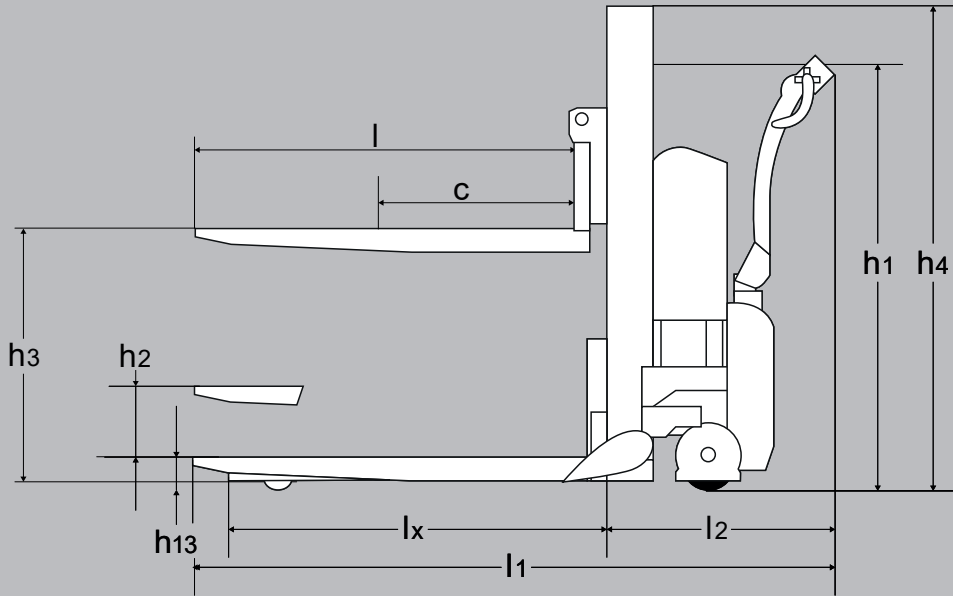

PRODUCT (measured in mm)		SELF MINI	SELF MINI
Adjustable fork carriage ¹		●	●
Fixed forks ¹			
Capacity in kg		1000 kg	1000 kg
Lifting height with wrap-over forks	h_3	920	1650
Fork length	l	1067, 1150	
Overall height	h_1	1320	1350
Overall width	b_1	635	635
Fork span - wrap-over ²	b_5	350-560	
Length without forks	l_2	620	630
Overall length with 1150 forks	l_1	1825	1835
Telescopic mast			●
Overall height	h_4	1320	2025
Lowered height - wrap-over forks ²	h_{13}	90	
Load centre	c	1/2	
Width between legs:	b_4	316, 436	
Fork width - wrap-over forks ²	e	163	
Run-in length	l_x	1100 with 1150mm forks	
Gangway (pallet: 1200 x 800)	A_{st}	2200 - tests show that 1700 mm are enough - depends on b_4	
Free lift	h_2		620
Turning angle of wheels		210°	
Motor		0,7 kW 24 V speed control electronically variable	
Drivingspeed with/without load		Below 500 mm lift: 5,2/5,5 km/h, over 500 mm lift: 3/4 km/h	
Pump motor		1,2 kW 24 V	
Lifting speed with/without load		0,07/0,12 m/s	
Lowering speed with/without load		0,12/0,07 m/s	
Weight in kg (without battery):		308 kg	363 kg

¹ This sheet shows our most popular Logiflex models. Other fork configurations are also available.

² For other fork styles go to p. 23.

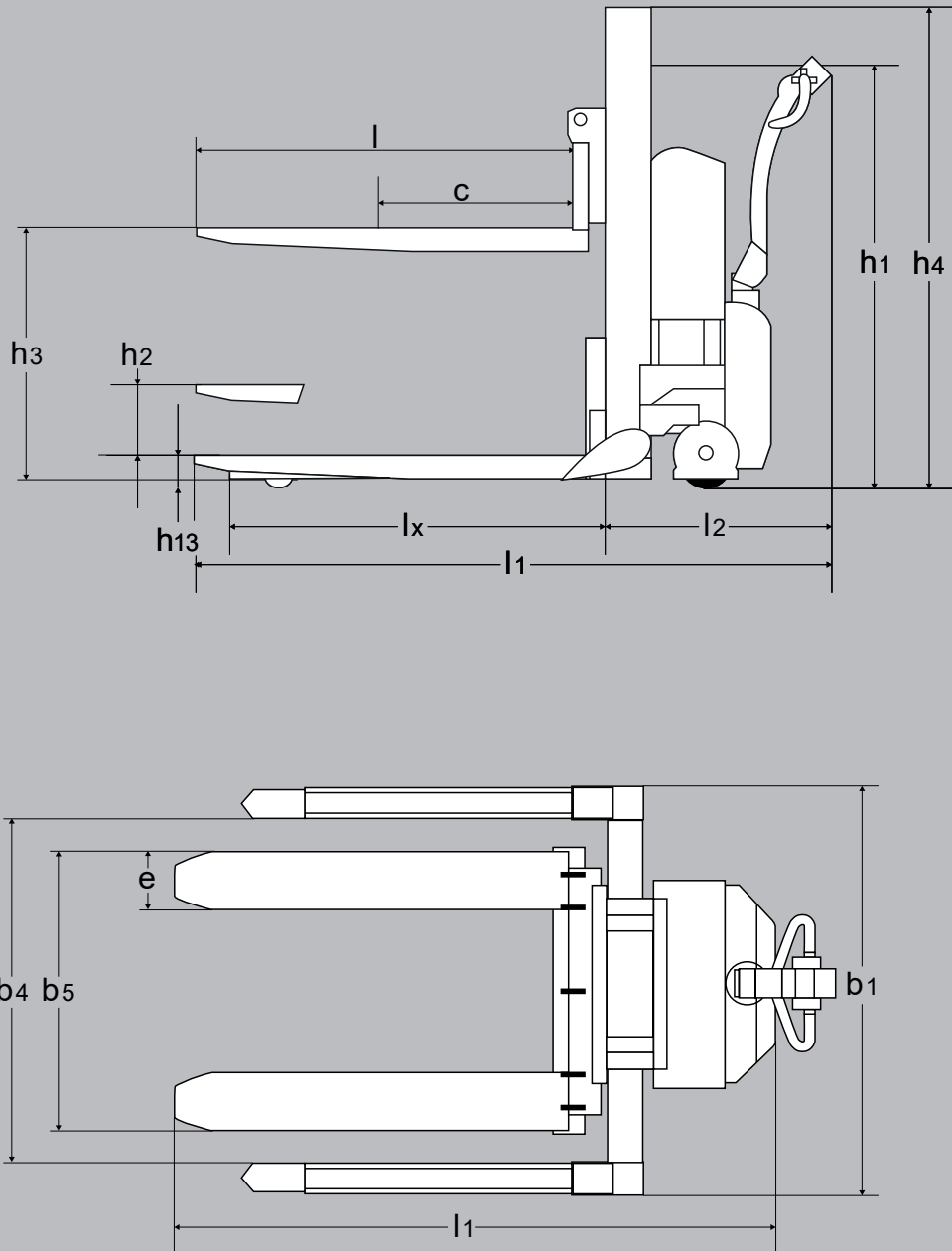

PRODUCT (measured in mm)		SELSMINI	SELSMINI
Adjustable fork carriage ¹		●	●
Capacity in kg		1000 kg	1000 kg
Lifting height with wrap-over forks	h_3	890	1620
Fork length	l	600/800/1067/1150/1520 ³	
Overall height	h_1	1320	1350
Overall width	b_1	166 + b_4	
Fork span - wrap-over ²	b_5	350-800	
Fork span - chisel ²	b_5	230-680	
Length without forks	l_2	620	630
Overall length with 1150 forks	l_1	1825	1835
Telescopic mast			●
Overall height	h_4	1320	1995
Lowered height - wrap-over forks ²	h_{13}	65	
Lowered height - chisel ²	h_{13}	40	
Load centre	c	1/2	
Width between legs:	b_4	850-942, 942-1124, 1124-1306, 1240-1422 ⁴	
Forkwidth - wrap-over ²	e	163	
Forkwidth - chisel forks ²		100	
Run-in length	l_x	1080 with 1150mm forks	
Gangway (pallet: 1200 x 800)	A_{st}	2200 - tests show that 1700 mm are enough - depends on b_4	
Free lift	h_2		620
Turning angle of wheels		210°	
Motor		0,7 kW 24 V speed control electronically variable	
Driving speed with/without load		Below 500 mm lift: 5,2/5,5 km/h, over 500 mm lift: 3/4 km/h	
Pump motor		1,2 kW 24 V	
Lifting speed with/without load		0,07/0,12 m/s	
Lowering speed with/without load		0,12/0,07 m/s	
Weight in kg (without battery):		348 kg	403 kg

¹ This sheet shows our most popular Logiflex models. Other fork configurations are also available.

² For other fork styles go to p. 23.

³ Reduced capacity 750 kg.

⁴ Width between straddle legs of more than 1306 mm: Max. capacity 800 kg.
Fork length of 1520 mm is not recommended.

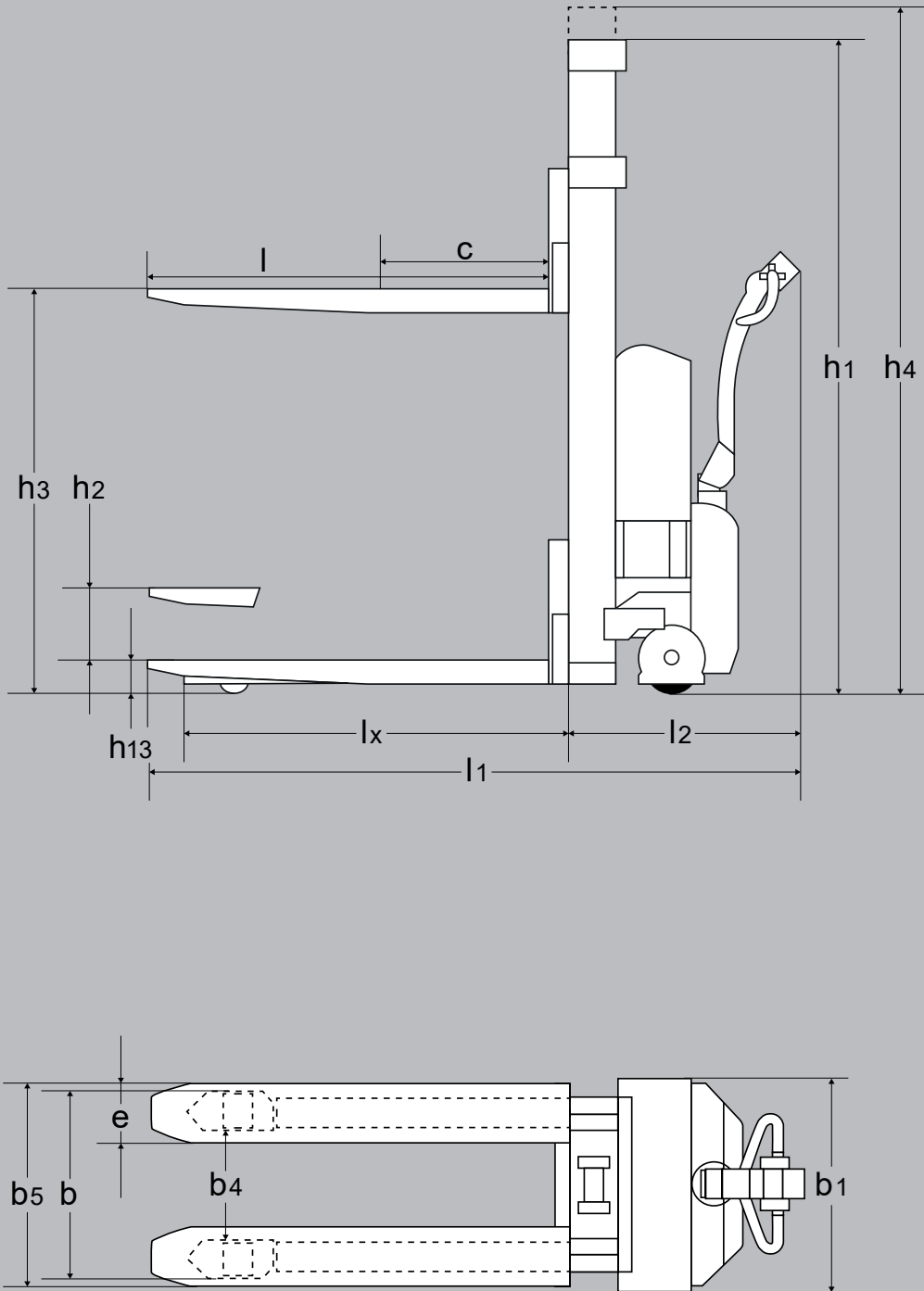

PRODUCT (measured in mm)		SELF MAXI	SELF MAXI	SELF MAXI	SELF MAXI	SELF MAXI	SELF MAXI	SELF MAXI	SELF MAXI	SELF MAXI	SELF MAXI
Fixed forks		●	●	●	●	●	●	●	●	●	●
Capacity in kg		1000/ 1200 kg	1000/ 1200 kg	1000/ 1200 kg	1000/ 1200 kg	1000 kg	1000 kg	1000 kg ³	1000 kg	1000 kg ³	1000 kg ³
Lifting height with wrap-over forks	h_3	920	1200	1400	1600	1910	2050	2450	2450	2850	3300
Fork length	l	600 ⁴ , 800 ⁴ , 1150, 1520 ⁵									
Overall height	h_1	1320	1530	1730	1930	2240	1530	1730	1730	1930	2240
Chassis span	b	460, 540 660	540, 660								
Overall width	b_1	635						890			
Width between legs	b_4	316, 436									
Fork span - wrap-over	b_5	560-680									
Length without forks	l_2	605									
Overall length with 1150 forks	l_1	1820					1830				
Telescopic mast							●	●	●	●	●
Overall height	h_4	Without telescopic mast					2490	2890	2890	3290	3740
Lowered height - wrap-over forks	h_{13}	90									
Load centre	c	1/2									
Forkwidth - wrap-over	e	163									
Run-in length	l_x	1100 with 1150 forks									
Gangway (pallet 1200 x 800)	A_{st}	2200 - tests show that 1700 mm are enough									
Free lift	h_2						190				
Turning angle of wheels		210°									
Motor		1,2kW 24 V speed control electronically variable									
Drivingspeed with/without load		Below 500 mm lift: 5/6 km/h, over 500 mm lift: 3/4 km/h									
Pump motor		1,2kW 24 V									
Lifting speed with/without load		Cap. 1000 kg: 0,07/0,12 m/s, cap. 1200 kg: 0,04/0,07 m/s									
Lowering speed with/without load		0,12/0,07 m/s					0,12/0,08 m/s				
Weight in kg (no battery): Cap. 1000/1200 kg		351kg	370 kg	376 kg	380 kg	388 kg	431kg	438 kg	445 kg	454 kg	468 kg

³ Load reduction at large lifting height.

⁴ Maximum lifting height 1600 mm with 600 mm forks, maximum lifting height 2450 mm with 800 mm forks.

⁵ Reduced capacity 750 kg. Not available for 1200 kg models.

⁶ Only for 1000 kg models.

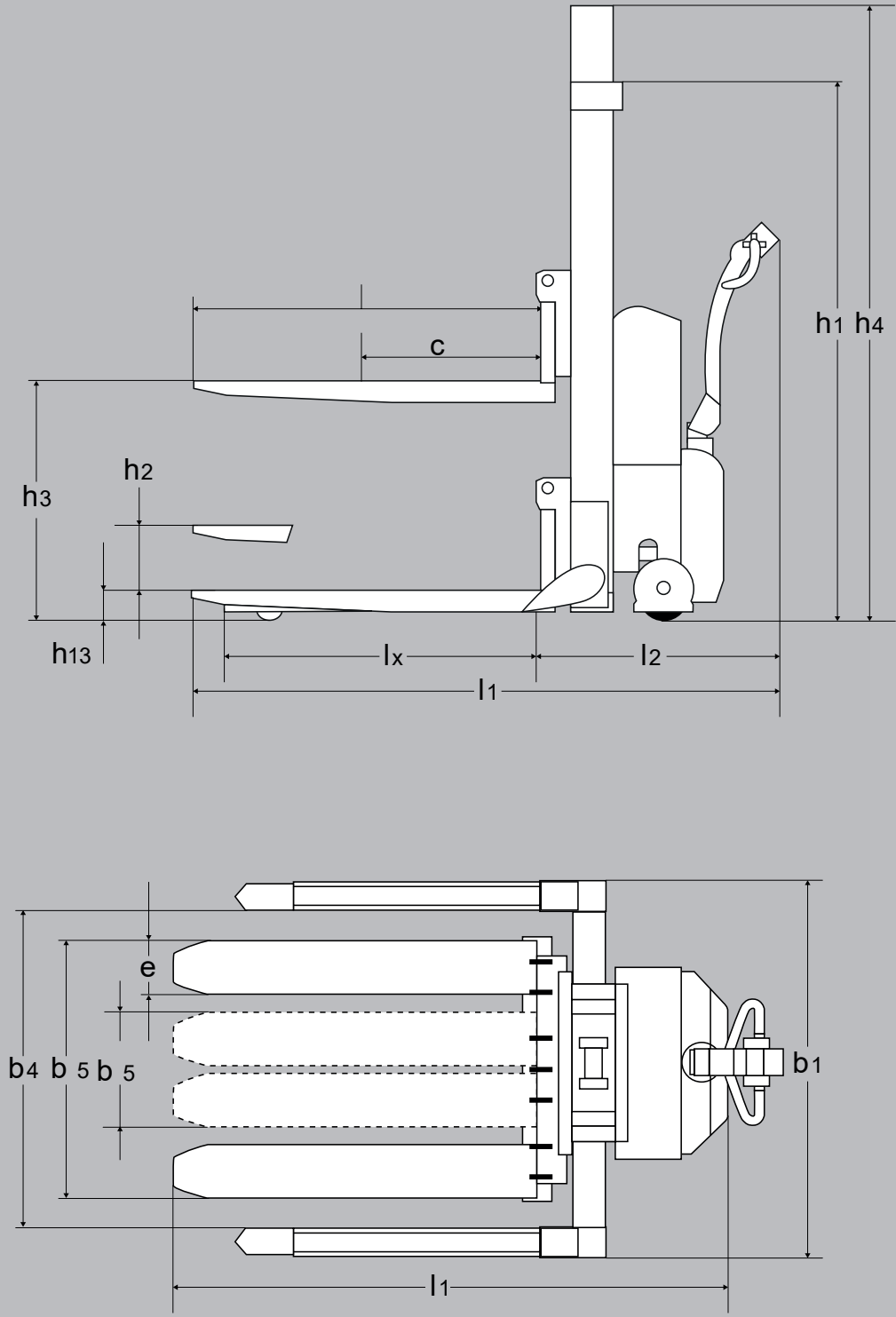

PRODUCT (measured in mm)		SELFS MAXI	SELFS MAXI	SELFS MAXI	SELFS MAXI	SELFS MAXI	SELFS MAXI	SELFS MAXI	SELFS MAXI	SELFS MAXI	
Adjustable fork carriage ¹		●	●	●	●	●	●	●	●	●	
Capacity in kg		1000/ 1200 kg ³	1000/ 1200 kg ³	1000/ 1200 kg ³	1000/ 1200 kg ³	1000 kg	1000 kg	1000 kg	1000 kg	1000 kg	
Lifting height forks: Wrap-over/chisel		h ₃ 890/ 870	1170/ 1150	1370/ 1350	1570/ 1550	1880/ 1860	2020/ 2000	2420/ 2400	2420/ 2400	2820/ 2800	
Fork length		l	600 ⁴ , 800 ⁴ , 1150, 1520 ⁵								
Overall height		h ₁	1320	1530	1730	1930	2240	1530	1730	1930	2240
Overall width		b ₁	166 + b ₄								
Fork span min./max.- wrap-over ²		b ₅	350-800								
Fork span min./max.- chisel ²			230-680								
Length without forks		l ₂	710								
Overall length by 1150 forks		l ₁	1855				1865				
Telescopic mast							●	●	●	●	
Overall height		h ₄	Without telescopic mast				2490	2890	3290	3740	
Lowered height - wrap-over forks ²		h ₁₃	65								
Lowered height - chisel ²			40								
Load centre		c	1/2								
Width between legs: Cap.1000/1200 kg		b ₄	S: 850-942, M: 942-1124, L: 1124-1306, XL: 1240-1422 ⁶ / S: 850-942, M: 942-1124, L: 1124-1306								
Forkwidth - wrap-over ²		e	163								
Forkwidth - chisel ²			100								
Run-in length		l _x	960 by 1150 and 1067 fork length								
Gangway (pallet: 1200 x 800)		A _{st}	2200 - tests show that 1700 mm are enough - depends on width between straddle legs								
Free lift		h ₂					190				
Turning angle of wheels			210°								
Driving motor			1,2kW 24 V speed control electronically variable								
Driving speed with/without load			Below 500 mm lift: 5/6 km/h, over 500 mm lift: 3/4 km/h								
Pump motor			1,2kW 24 V								
Lifting speed with/without load			Cap. 1000 kg: 0,07/0,12 m/s, cap. 1200 kg: 0,04/0,07 m/s								
Lowering speed with/without load			0,12/0,07 m/s				0,12/0,08 m/s				
Weight in kg (no battery):			411 kg	430 kg	436 kg	440 kg	448 kg	491 kg	498 kg	507 kg	521 kg

¹ This sheet shows our most popular Logiflex models. Other fork configurations are also available.

² For other fork styles go to p. 23.

³ 1200 kg models are only available with fork length options: Chisel forks: 1067 and 1200 mm., wrap-over forks: 1067 and 1150mm.

⁴ Maximum lifting height 1570mm by 600 mm fork length, maximum lifting height 2420 by 800 mm fork length.

⁵ Reduced capacity 750 kg.

⁶ Width between straddle legs of more than 1306 mm:

Max. capacity 800 kg.





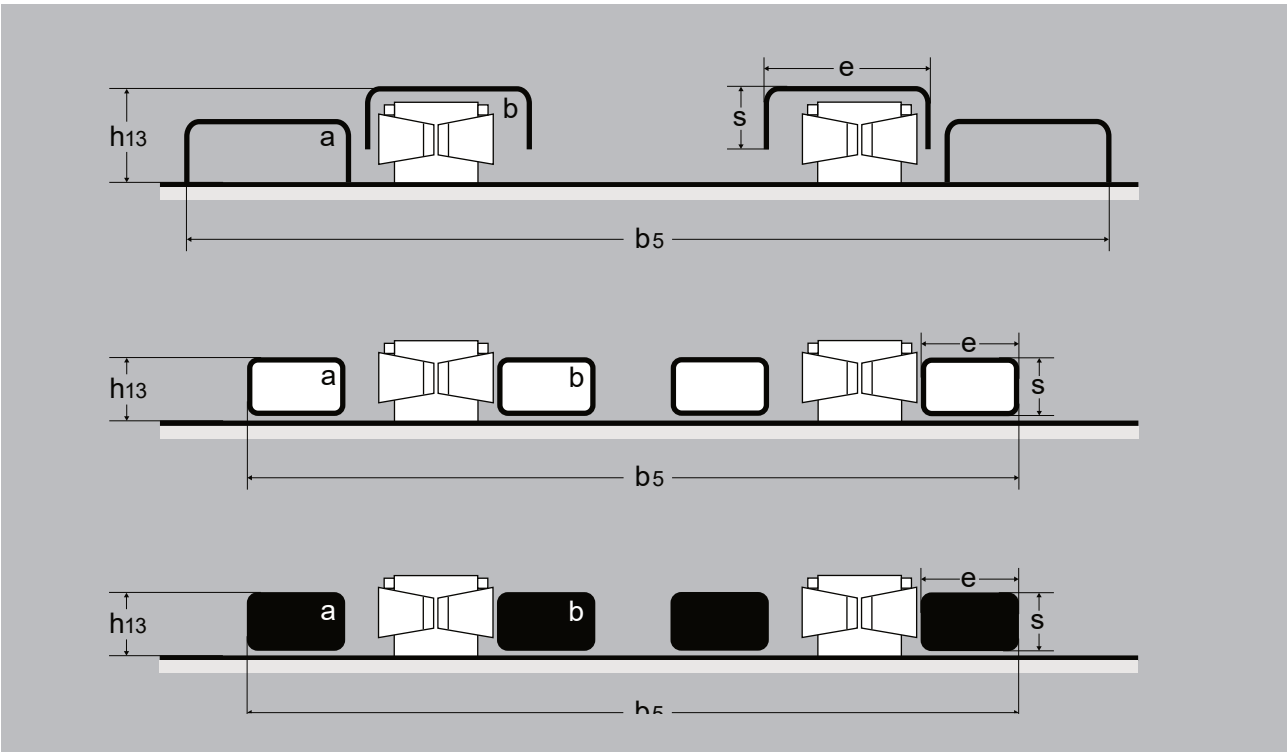

Fork length of 1520 mm is not recommended.

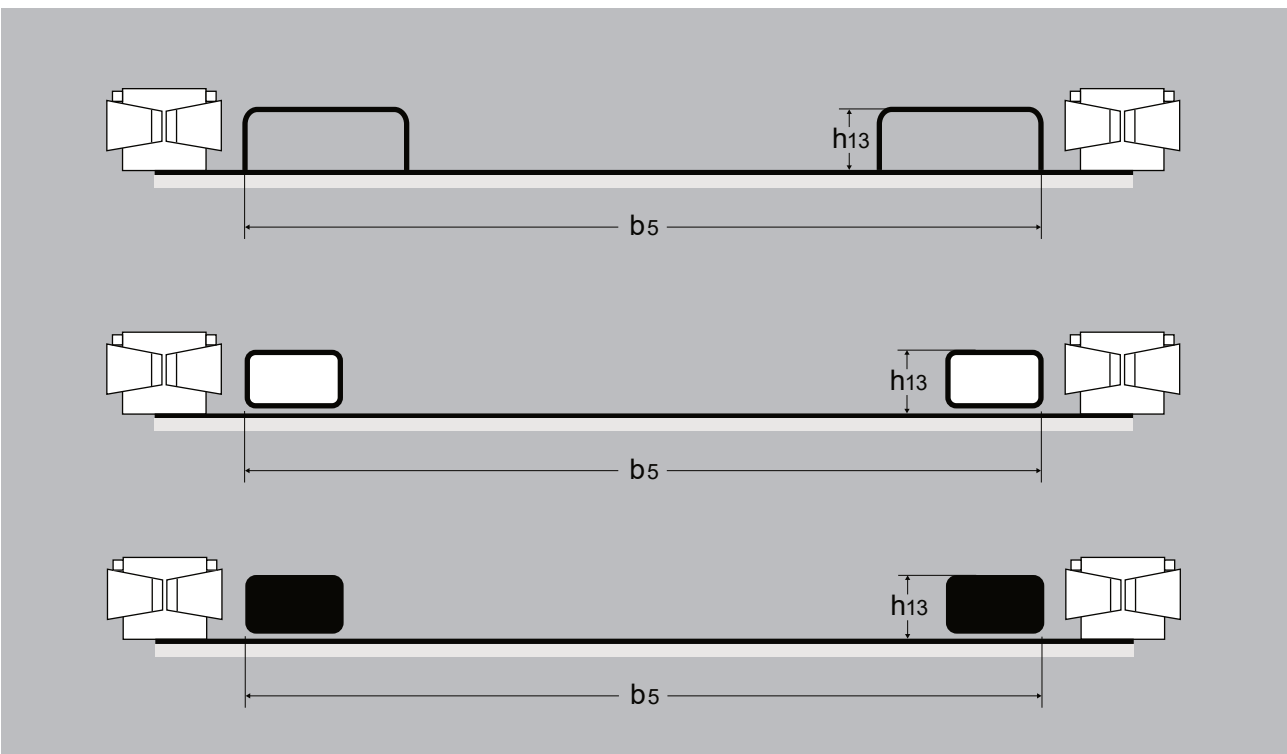





WITHOUT STRADDLE



WITH STRADDLE



PRODUCT (measured in mm)		FORK CARRIAGE 440 mm ¹			FORK CARRIAGE 690 mm ²		
		Wrap-over 	Bar 	Chisel 	Wrap-over 	Bar 	Chisel 
Fork style							
Size of wheel		Ø85			Ø85		
Fork span	b ₅	350-560	230-430	230-430	350-800	230-680	230-680
Fork span - a	b ₅						
Fork span - b	b ₅	560	230-300	230-300	560	230-300	230-300
Lowered fork height - straddle legs	h ₁₃	85	85	60	65	65	40
Lowered fork height - a	h ₁₃						
Lowered fork height - b	h ₁₃	90	85	60	90	65	40
Fork width	e	163	100	100	163	100	100
Fork height	s	61	60	35	61	60	35

PRODUCT (measured in mm)		FORK CARRIAGE 810 mm ³			FORK CARRIAGE 946 mm		
		Wrap-over 	Bar 	Chisel 	Wrap-over 	Bar 	Chisel 
Fork style							
Size of wheel		Ø85			Ø85		
Fork span	b ₅	350-920	230-800	230-800	530-1050	420-930	420-930
Fork span - a	b ₅	876-920	750-800	750-800	876-1050	750-930	750-930
Fork span - b	b ₅	560	230-300	230-300	560		
Lowered fork height - straddle legs	h ₁₃	65	65	40	65	65	40
Lowered fork height - a	h ₁₃	65	65	40	65	65	40
Lowered fork height - b	h ₁₃	90	65	40			
Fork width	e	163	100	100	163	100	100
Fork height	s	61	60	35	61	60	35

¹ Standard carriage for LF MINI and ELF with capacity 1000 kg and lifting height 920 and 1650 mm.

² Standard carriage for Logiflex straddle stackers with wrap-over forks.

³ Standard carriage for Logiflex straddle stackers with bar and chisel forks.

Standard carriage for Logiflex stackers without straddle legs (but fork carriage 440 mm for LF MINI and ELF with capacity 1000 kg and lifting height 920 and 1650 mm).

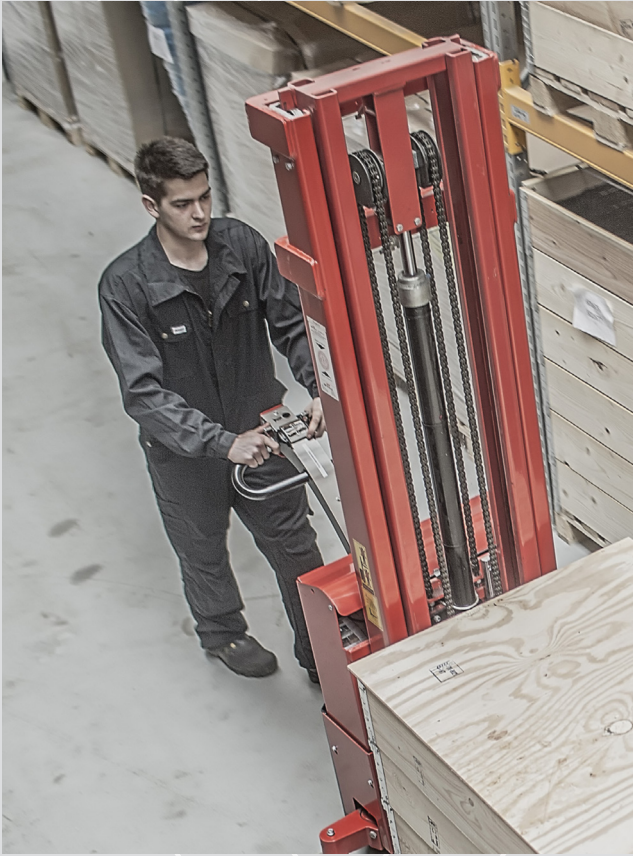

Bloms AB

www.bloms.com | info@bloms.com | +46 33 15 70 75